

**•General Description**

The SGT MOSFET LH018N04G has the low  $R_{DS(on)}$ , low gate charge, fast switching and excellent avalanche characteristics. This device is suitable for fast charge and lighting.

**•Features**

- Fast switching
- Low  $R_{DS(on)}$  & FOM
- Low Gate Charge

**•Application**

- LED/LCD/PDP TV and monitor Lighting
- Power Supplies
- DC/DC Converters

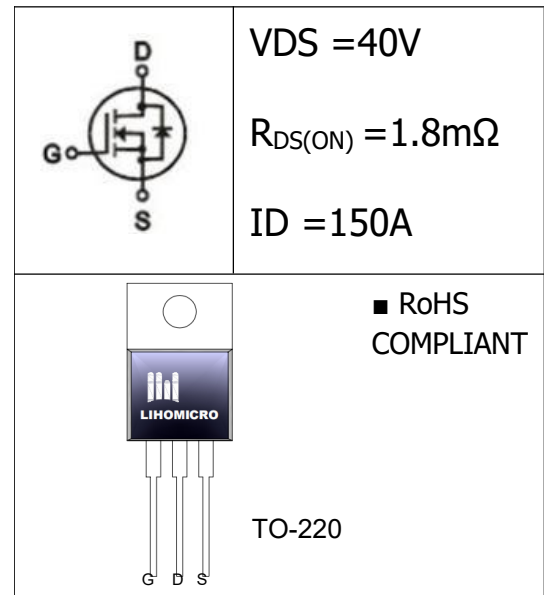
**•Ordering Information:**

Part Number	LH018N04G
Package	TO-220
Basic Ordering Unit (pcs)	1000
Normal Package Material Ordering Code	LH018N04GT-TO220-TU
Halogen Free Ordering Code	LH018N04GT-TO220-TU-HF

**•Absolute Maximum Ratings (TC =25°C)**

PARAMETER	SYMBOL	Value	UNIT
Drain-Source Breakdown Voltage	$BV_{DSS}$	40	V
Gate-Source Voltage	$V_{GS}$	$\pm 20$	V
Continuous Drain Current , $T_C = 25^\circ C$	$I_D$	150	A
Pulsed drain current (TC = 25°C, tp limited by Tjmax) <sup>1</sup>	$I_D$ pulse	400	A
Single Pulse Avalanche Energy <sup>2</sup>	$E_{AS}$	400	mJ
Power Dissipation(TC=25°C)	$P_D$	125	W
Operating Temperature	$T_J$	-55~+150	°C
Storage Temperature	$T_{STG}$	-55~+150	°C

**●Electronic Characteristics**

PARAMETER	SYMBOL	TEST CONDITION	MIN	TYP	MAX	UNIT
Drain-Source Breakdown Voltage	$BV_{DSS}$	$V_{GS}=0V, I_D=250\mu A$	40	--	--	V
Gate Threshold Voltage	$V_{GS(TH)}$	$V_{DS}=V_{GS}, I_D=250\mu A$	1.2	1.6	2.2	V
Drain-source On Resistance <sup>3</sup>	$R_{DS(ON)}$	$V_{GS}=10V, I_D=20A$	--	1.5	1.8	mΩ
		$V_{GS}=4.5V, I_D=20A$	--	2.0	2.6	
Drain-Source Leakage Current	$I_{DSS}$	$V_{DS}=32V, V_{GS}=0V, T_J=25^\circ C$	--	--	1	μA
		$V_{DS}=32V, V_{GS}=0V, T_J=85^\circ C$	--	--	5	
Gate-Source Leakage Current	$I_{GSS}$	$V_{GS}=\pm 20, V_{DS}=0V$	--	--	±100	nA
Input Capacitance	$C_{iss}$	$V_{GS}=0V,$ $V_{DS}=20V$ $f=1.0MHz$	--	3975	--	pF
Output Capacitance	$C_{oss}$		--	1200	--	
Reverse transfer Capacitance	$C_{rss}$		--	82	--	
Turn -Off Delay Time	$T_d(off)$	$V_{GS}=10V,$ $I_D=20.0A$ $R_G=3.3\Omega$	--	60	--	ns
Turn-on delay time	$T_d(on)$		--	18	--	
Rise time	$T_r$		--	9	--	
Fall time	$T_f$		--	32	--	
Total Gate Charge	$Q_g$	$I_D=20A,$ $V_{DS}=15V$ $V_{GS}=10V$	--	46	---	nC
Gate-to-Source Charge	$Q_{gs}$		--	12	--	
Gate-to-Drain Charge	$Q_{gd}$		--	18	---	
Continuous Diode Forward Current	$I_S$	--	--	--	150	A
Pulsed Diode Forward Current	$I_{SM}$	--	--	--	400	A
Diode Forward Voltage	$V_{SD}$	$T_J=25^\circ C, I_S=10.0A$ $V_{GS}=0V$	--	--	1.2	V

**●Thermal Characteristics**

PARAMETER	SYMBOL	MAX	UNIT
Thermal Resistance Junction-case	$R_{thJC}$	1.0	°C/W
Thermal Resistance Junction-ambient	$R_{thJA}$	50	°C/W

Notes:

- 1.Repetitive Rating: Pulse width limited by maximum junction temperature.
2.  $I_{AS}=40A, V_{DD}=25V, R_G=25\Omega, \text{Starting } T_J=25^\circ C$
3. Pulse Test : Pulse width ≤ 300μs, Duty cycle ≤ 2%

• **Typical Characteristics**

**Fig.1 Typical Output Characteristics**

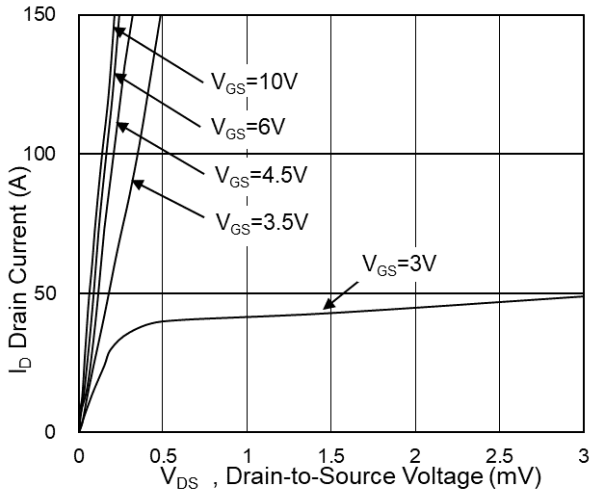

**Fig.2 On-Resistance vs G-S Voltage**

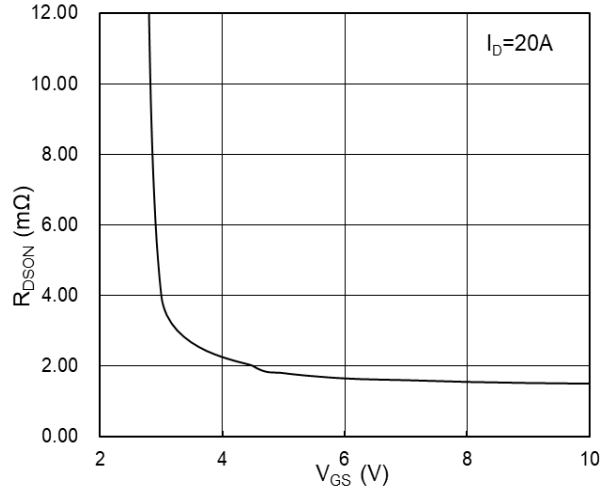

**Fig.3 Source Drain Forward Characteristics**

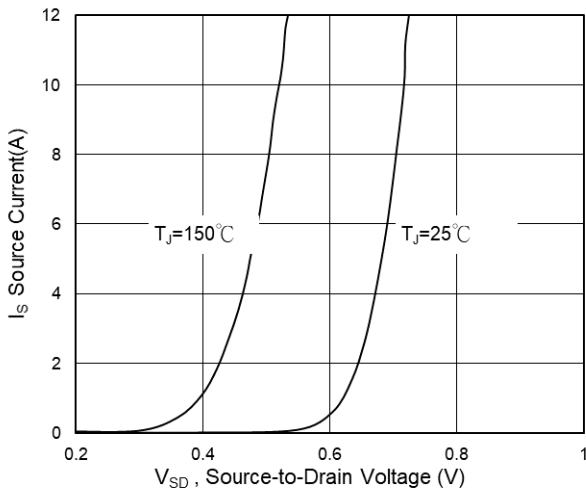

**Fig.4 Capacitance**

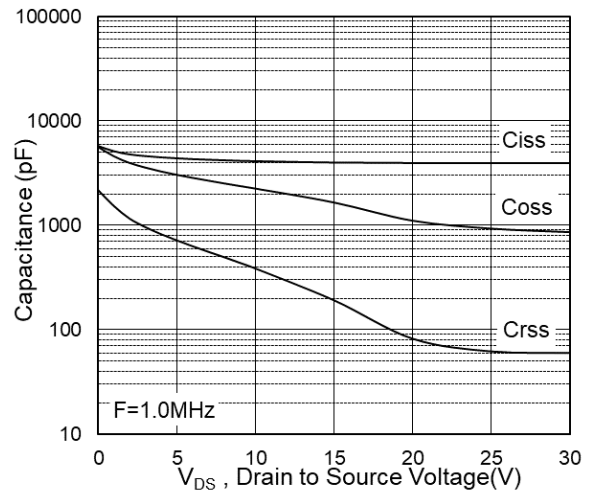

**Fig.5 Normalized  $V_{GS(th)}$  vs  $T_J$**

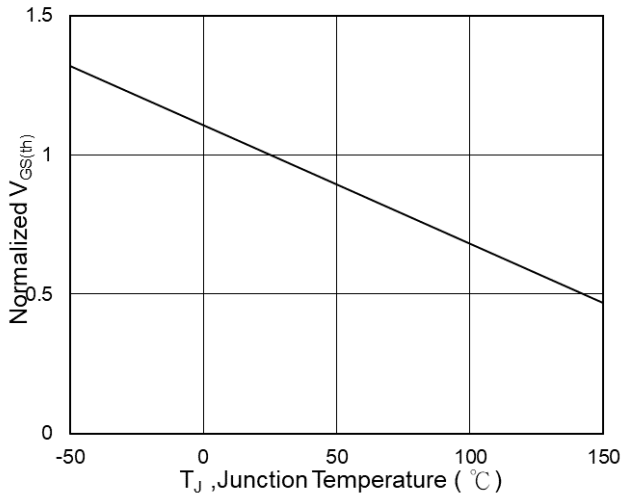

**Fig.6 Gate-Charge Characteristics**

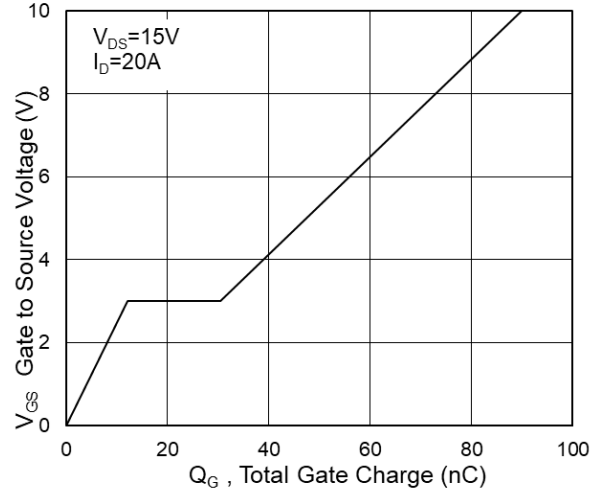

•Typical Characteristics(cont.)

Fig.7 Normalized R<sub>DS(on)</sub> vs T<sub>J</sub>

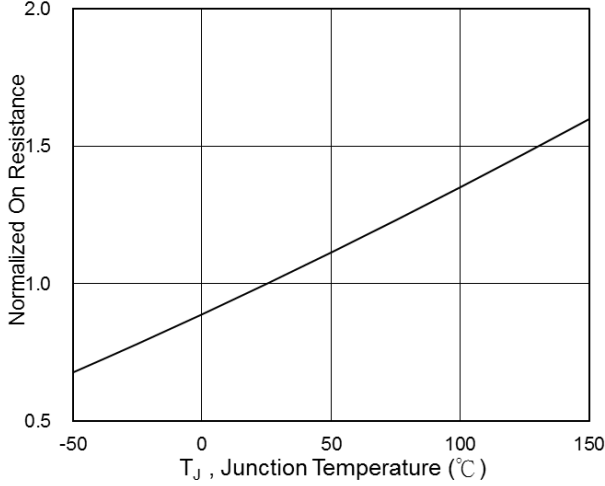

Fig.8 Safe Operating Area

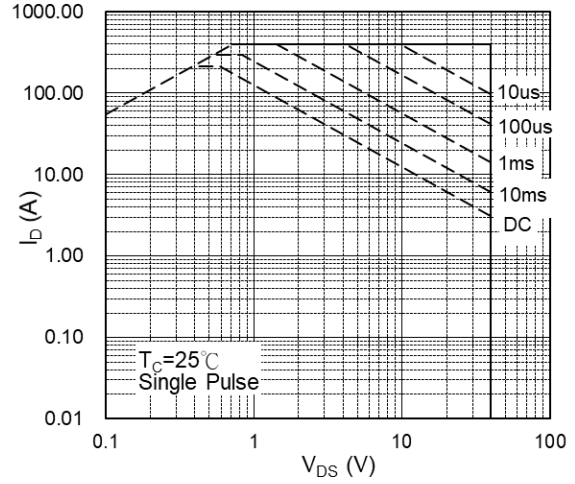
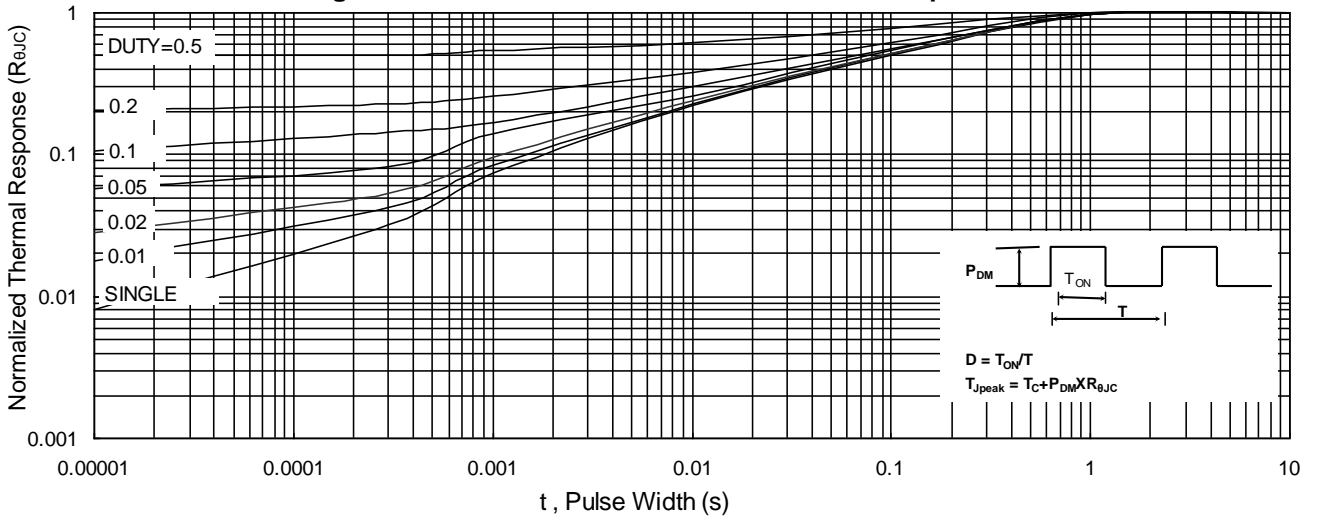

Fig.9 Normalized Maximum Transient Thermal Impedance



• Test Circuits & Waveforms

Fig1.EAS test Circuits

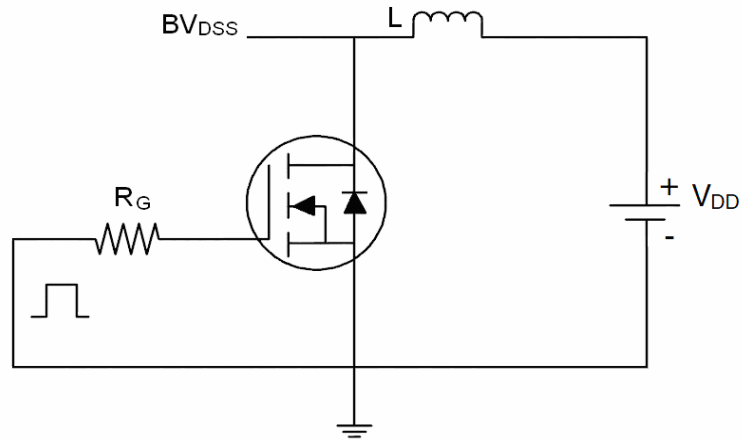

Fig2.Gate charge test Circuit

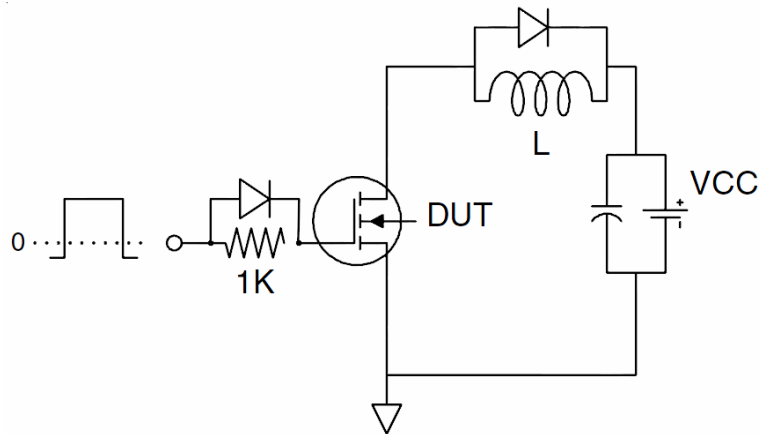
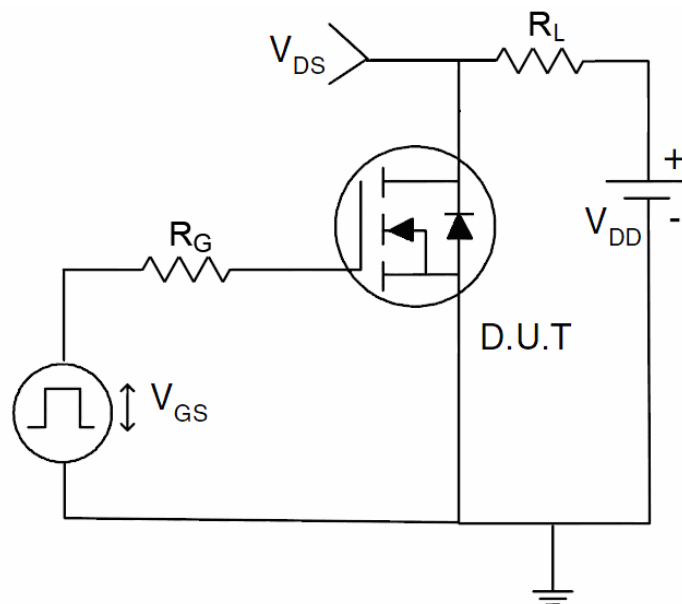

Fig3.Switch Time Test Circuit



•Dimensions (TO-220)

Unit: mm

SYMBOL	min	max	SYMBOL	min	max
A	4.25	4.85	B1	2.60	3.00
A1	2.30	3.00	e	2.40	2.70
A2	1.20	1.40	e1	4.95	5.25
b	0.60	0.90	L	12.60	14.40
b1	1.10	1.70	L1	2.40	4.00
c	0.40	0.70	∅P	3.50	3.90
D	9.80	10.60			
B	15.20	16.20			

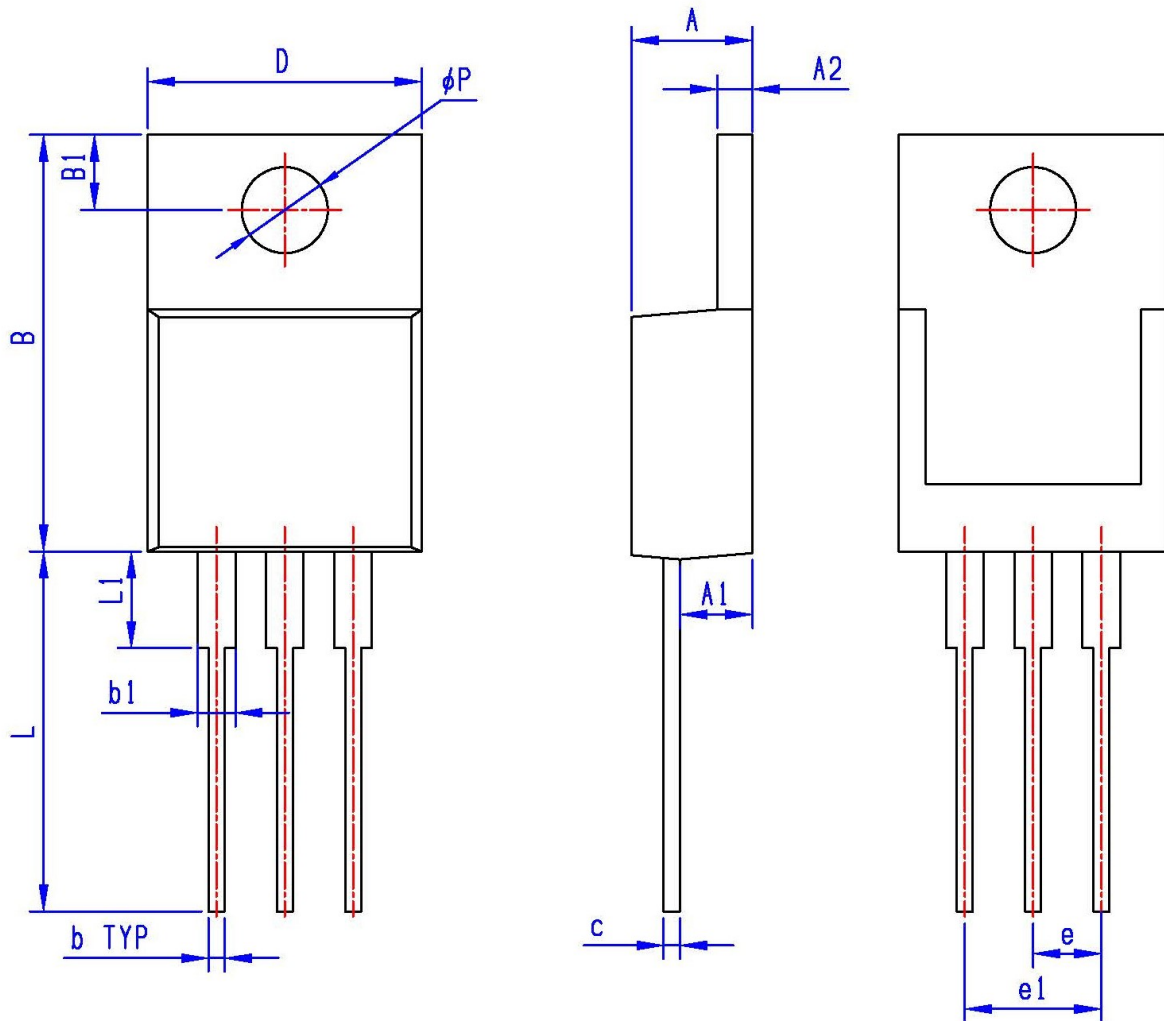

**• Soldering Methods for Silicongear's Products**

1. Storage environment: Temperature=10°C to 35°C Humidity=65%±15%
2. Reflow soldering of surface-mount devices

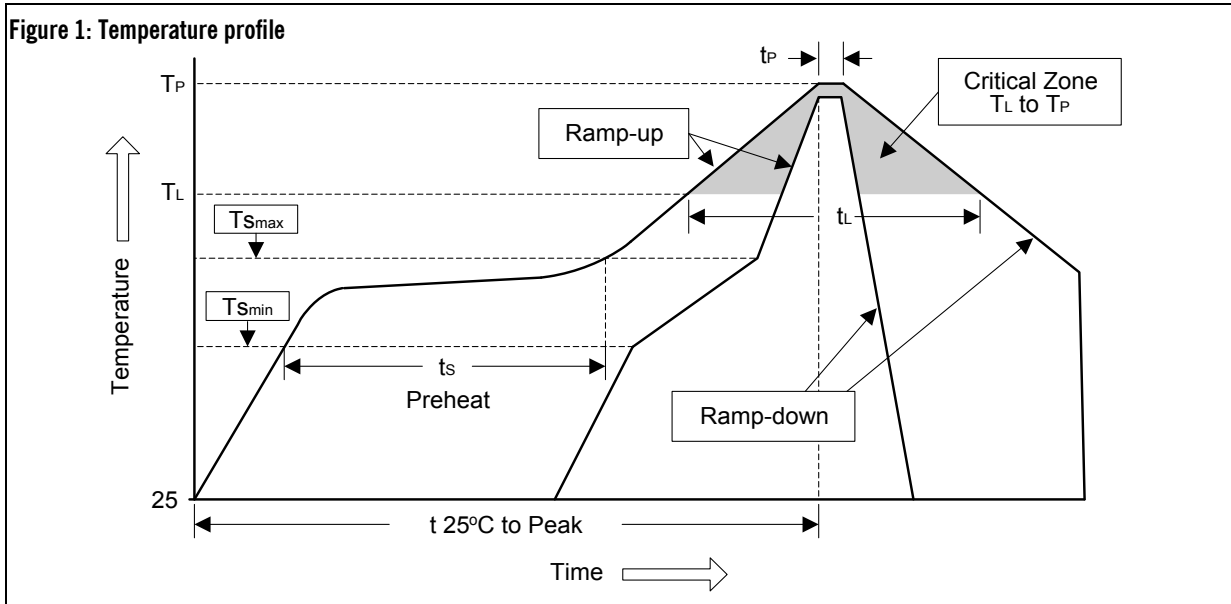

Profile Feature	Sn-Pb Eutectic Assembly	Pb-Free Assembly
Average ramp-up rate ( $T_L$ to $T_P$ )	< 3°C/sec	< 3°C/sec
Preheat		
- Temperature Min ( $T_{Smin}$ )	100°C	150°C
- Temperature Max ( $T_{Smax}$ )	150°C	200°C
- Time (min to max) ( $t_s$ )	60 to 120 sec	60 to 180 sec
$T_{Smax}$ to $T_L$		
- Ramp-up Rate	< 3°C/sec	< 3°C/sec
Time maintained above:		
- Temperature ( $T_L$ )	183°C	217°C
- Time ( $t_L$ )	60 to 150 sec	60 to 150 sec
Peak Temperature ( $T_P$ )	240°C +0/-5°C	260°C +0/-5°C
Time within 5°C of actual Peak Temperature ( $t_p$ )	10 to 30 sec	20 to 40 sec
Ramp-down Rate	< 6°C/sec	< 6°C/sec
Time 25°C to Peak Temperature	< 6 minutes	< 8 minutes

**3. Flow (wave) soldering (solder dipping)**

Products	Peak Temperature	Dipping Time
Pb devices.	245°C ±5°C	5sec ±1sec
Pb-Free devices.	260°C +0/-5°C	5sec ±1sec